

Manual ———

Geo City

EN



CONGRATULATIONS

With your new LOOK pedals, the adventure can finally begin.

Our products meet current European and international standards.

Thank you for choosing our high-tech, premium quality French product. We hope you enjoy the ride! Like the vast majority of LOOK products, they are identical to the pedals provided to professional athletes,

Please read these instructions fully before use and follow all the advice given in order to make the most of this high-quality product.

and are checked throughout the manufacturing process to ensure complete satisfaction.

LOOK reserves the right to change the product specifications without prior notice in order to improve it.

GEO CITY



GEO CITY
VISION GRIP



GEO CITY
GRIP



Pedals Differentiation Summary Tableentre les pédales

| Product | Set of pedals | Activ Grip pads x4 | Lights x4 |
|----------------------|---------------|--------------------|-----------|
| GEO CITY | X | | |
| GEO CITY GRIP | X | X | |
| GEO CITY GRIP VISION | X | X | X |
| Kit Pad ACTIV GRIP | | X | |

LIFESPAN - USE - REQUIRED INSPECTIONS

All our axles are only approved following extremely demanding testing, above and beyond the current standard (ISO 4210).

The lifespan of LOOK components depends on many factors, such as their use and the cyclist's height and weight. Impacts, falls, improper use or rough use in general can compromise the structural integrity of the components and significantly reduce their lifespan.

Some components are also subject to wear over time. Have your pedals inspected regularly by an

authorised LOOK retailer to check for cracks, warping, signs of fatigue or wear. If the inspection reveals warping, cracks, dents or stress marks, however slight, immediately replace the component in question; components that have undergone excessive wear must also be replaced immediately. The frequency of inspection depends on many factors; consult your authorised LOOK retailer.

Component must be replaced by an authorised LOOK dealer.

The list of replaceable components is available from authorised LOOK retailers.

READ IN ADVANCE!

When cycling, always wear a helmet and follow the rules of the road. Pay attention to the road and traffic. Stay up to date with all relevant local laws. If you are cycling at night, you need to be able to see and be seen. The optional reflectors and lights provided with the VISION versions are not adequate and cannot be used in place of front and rear lights. Wearing reflective garments is highly recommended or even mandatory in some countries.

For more IMPORTANT INFORMATION, please consult our website www.lookcycle.com WARRANTY POLICY section > IMPORTANT INFORMATION.

INSTALLING THE PEDALS ON THE CRANK ARMS

Product concerned: **GEO CITY / GEO CITY GRIP / GEO CITY GRIP VISION**

Before installing your pedals, ensure the screw threads on the crank arms are BSA standard (9/16x20).

1 - Clean and grease the crank arm threads before inserting the pedal.

2 - Locate the left pedal, marked with a ring around the axle (See diagram A).

3 - Facing the left-hand pedal, tighten it clockwise using an 8mm Allen key, to a torque of 25Nm (figure B).

4 - Facing the right-hand pedal, tighten it counterclockwise using an 8mm Allen key, to a torque of 25Nm (figure B).

A / LOCATING THE LEFT AND RIGHT HAND PEDALS

Left pedal

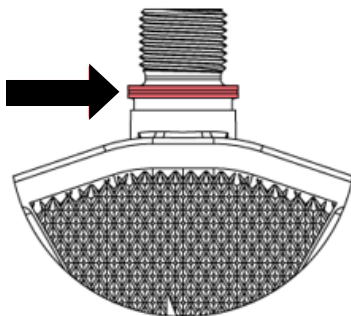

Ring

Right pedal

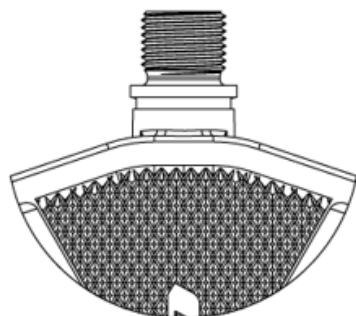

No ring / Smooth surface

B / TIGHTENING THE PEDAL ON THE CRANK ARM

Facing the right pedal :
tighten counterclockwise

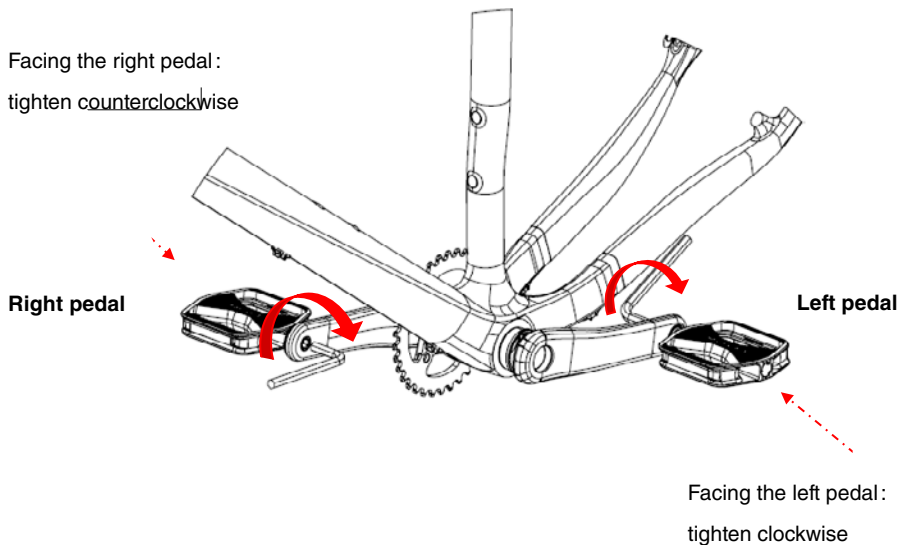

INSTALLING / REMOVING THE LIGHTS

Product concerned : **GEO CITY GRIP VISION**

C / REMOVING THE LIGHTS

Your VISION lights are delivered fully assembled on your GEO CITY VISION GRIP pedals. To charge them for the first time, please follow the removal procedure below.

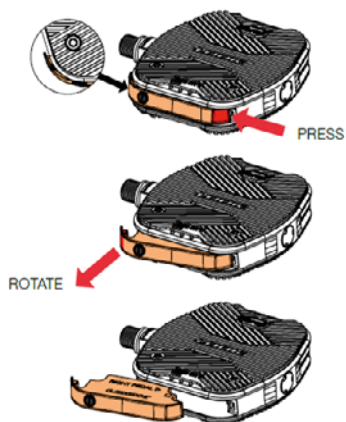

D / LOCATING THE RIGHT AND LEFT HAND LIGHTS

THE GEO CITY VISION GRIP pedals have two lights on each pedal. Ensure you mount the correct lights on each side as indicated below :

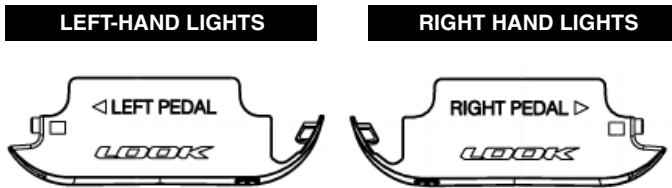

E / INSTALLING THE LIGHTS

For optimal performance, ensure that the lights and their housing are kept clean at all times.

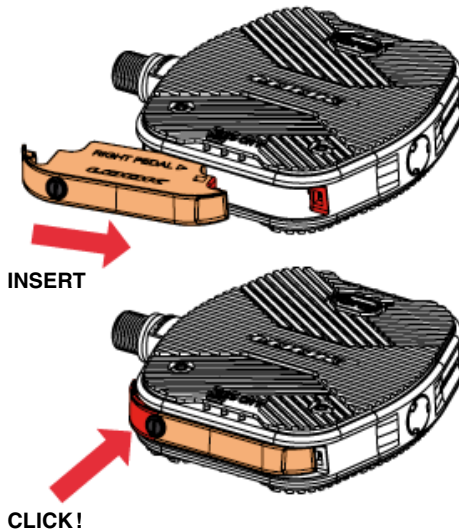

LOOK VISION LIGHTS

Product concerned: **GEO CITY GRIP VISION**

| Mode | Light | Battery runtime | Lumen | Charging time |
|--------|-----------|-----------------|-------|---------------|
| MODE 1 | STEADY | 3:00 | 20 | 2:00 |
| MODE 2 | DAY FLASH | 2:30 | 50 | |
| MODE 3 | FLASH | 6:30 | 10 | |
| MODE 4 | FLASH ECO | 20:00 | 6 | |

F / ON/OFF / MODE SWITCH

Long press (>1s) = Start-stop

Short press = Select light mode

- The lights automatically switch to standby mode after 30 seconds without movement.

- The green LED light blinks to indicate the lights are switched on. As soon as pedaling is resumed (or motion is detected), the lights restart in the last active mode.

- The lights will automatically power off if they do not detect motion for more than 30 minutes. A long press on the "mode" button is required to switch them on again.



G /CHARGE / BATTERY LEVEL INDICATOR

The LOOK VISION light batteries are charged in our factory up to a maximum of 30% for regulatory transport reasons.

It is therefore recommended that you charge them fully before first use.

For a correct recharge, it is recommended you charge the batteries in a dry environment at room temperature. Extreme conditions (humidity, negative or excessively high temperatures) must be avoided. Battery autonomy in the different modes is only guaranteed within a temperature range of -5°C/+40°C.

1 - Open the cap of the micro-USB port on the device.

2 - Plug the charging cable into the micro-USB port.

3 - Plug the second end of the charging cable into the USB port of a computer or an AC adapter.

4 - When charging is complete, unplug the cable and close the cap on the device.

In charge (USB plugged in)

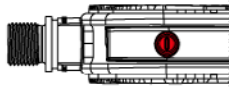
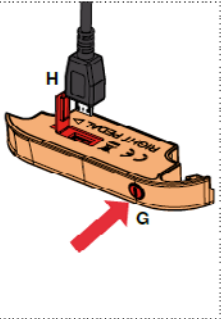
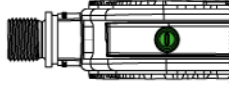
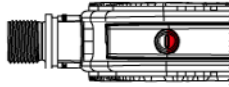
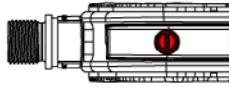
| | | | |
|--|------------------|-------------------------|---|
|  | Solid red LED | In charge |  |
|  | Solid green LED | Full charge | |
| In use  | Flashing red LED | Battery level below 30% | |
|  | Solid red LED | Battery level below 25% | |

 **Warning:** Check the local laws concerning lighting. Flashing lights are not permitted in some countries. LOOK VISION lights do not comply with German traffic law StVZO. LOOK Vision is additional lighting intended to make cyclists even more clearly visible. It is not a substitute for the lighting required by law.

 **Warning:** Before riding, ensure the micro-USB port cap is correctly closed to prevent the intrusion of any dirt or moisture that could interfere with charging. The initial battery autonomy (20h in eco flash mode) may decrease over time due to a number of factors: incorrect charging procedure, the number of charges or the ambient temperature during charging (temperature should be between -5° and 40° degrees Celsius, outside of which battery capacity may be significantly reduced). Leaving your batteries fully discharged for a significant amount of time can result in a progressive loss of their initial autonomy until complete and irreversible depletion. For this reason, always make sure to maintain a minimum charge level by recharging the batteries every 2 months at least.

RECYCLING

The batteries must be recycled. Do not throw the batteries away.

The logo opposite, displayed on the products themselves or their technical documents, indicates that devices with electronic components should not be mixed with normal household waste.

Contact the competent authorities in your country to find out the most appropriate way to recycle your batteries.

Recycling helps reduce the use of limited natural resources and prevents the possible negative effects that not recycling could have on the environment and human health.



INSTALLING / REMOVING THE PADS

Products concerned: **GEO CITY GRIP - GEO CITY GRIP VISION**

Your pedals are customizable and available in 4 different colors thanks to the ACTIV GRIP pads!

For optimal grip :

1 - Always keep your ACTIV GRIP pads clean.

2 - Please replace your ACTIV GRIP pads when they are damaged or worn.

3 - Never use GEO CTIY GRIP / TRAIL GRIP pedals without ACTIV GRIP pads.

4 - When installing or removing the pads, use only the T20 Torx wrench supplied with your ACTIV GRIP replacement pads.

5 - When installing, make sure to observe a tightening torque of 1 - 2 Nm.

6 - Do not oil or grease the screws and do not use thread locker.

7 - The ACTIV GRIP pads are only warranted up to 5 installation / removal procedures at the recommended torque.

Your ACTIV GRIP pad kit contains :



Activ Grip pad



4 Screws



T20 Torx wrench

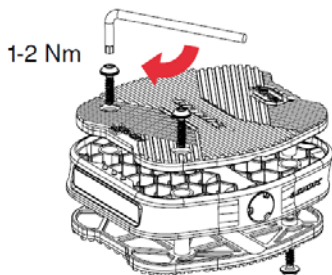

Pad assembly



Warning: If you wear shoes with smooth soles, your foot may slip in heavy rain.

MAINTENANCE

Always clean your pedals with soap or mild detergent and water.

Rinse them with water and dry with a soft cloth. Any heat source can irreparably damage your pedals and cleats. Do not use a high-pressure cleaning device or abrasive products.

Remember to also maintain your axles well. Please consult the axle line maintenance guide - flat pedals on our website www.lookcycle.com ASSISTANCE tab > INSTRUCTIONS

For more information on maintenance requirements, please visit www.lookcycle.com WARRANTY POLICY > MAINTENANCE

IT IS IMPORTANT TO CHECK AND MAINTAIN YOUR PRODUCT FOR YOUR SAFETY AND TO ENSURE A LONG PRODUCT LIFESPAN. POORLY MAINTAINED PEDAL CAN BREAK OR MALFUNCTION, WHICH COULD POTENTIALLY CAUSE AN ACCIDENT IN WHICH YOU COULD BE KILLED, SERIOUSLY INJURED OR PARALYSED.

AFTER-SALES SERVICE

Our manufacturing process is very thorough, however in the unlikely event of a defect if a repair is required, please take the defective product to your authorised LOOK retailer, together with your purchase receipt, and explain the defect.

WARRANTY

TO BENEFIT FROM AN ADDITIONAL YEAR OF WARRANTY COVERAGE (EXCLUDING LIGHTING), SAVE YOUR PROOF OF PURCHASE AND REGISTER YOUR PEDALS ONLINE WITHIN 30 DAYS OF YOUR PURCHASE. IN ADDITION, WE MAY CONTACT YOU TO PROVIDE IMPORTANT INFORMATION IN THE EVENT OF PRODUCT RECALLS OR POSSIBLE UPDATES.

REFER TO THE REGISTRATION MANUAL.

LOOK pedals are guaranteed for two years from the date of purchase against any manufacturing defects. Through the authorised distributors in the country in which the product was purchased, LOOK guarantees the product against any manufacturing defects for the first buyer or user.

This warranty does not apply to “Special Service Course” products and/or products purchased from professional, amateur or athletic teams, clubs, tenants or at auction, even if the product is new.

The warranty is only valid if the product has been assembled in accordance with the instructions above. The warranty does not cover damage caused by poor maintenance or improper usage.

The warranty is also rendered null and void if the product:

- Has undergone a technical and/or structural modification, or has been repaired or repainted outside of an authorised LOOK repair centre.
- Has been repaired and/or used with unauthorized spare parts.

This limited warranty does not apply to normal wear (including cleats), parts that have been repaired or subjected to improper repairs or modifications, or damage caused by an accident, improper or inappropriate use, or a lack of due diligence.

Spinning (indoor cycling) is considered such an inappropriate use and will render the warranty null and void.

The only recourse under the LOOK limited warranty or any implied warranty is limited to repairs or exchanges of all or part of the product concerned, at the sole discretion of look. Under no circumstances can LOOK and its agents or distributors be held liable for any direct or consequential damage, or for the cost of transporting or shipping the product, regardless of whether the claim is based on the contract, the warranty, negligence or product liability, including but not limited to loss or damage related to any property other than the guaranteed product itself, loss of use of property or any other financial loss.

No matter the cause, neither LOOK nor its agents or distributors can be held liable for any financial contributions or product compensation. The rights granted by the warranty and the benefits cannot be assigned or transferred.

LOOK's obligations under any warranty are limited to those specified in this LOOK limited warranty, according to the broadest interpretation of the law.

Some countries and states do not permit time limits on implied warranties and/or the exclusion or limitation of direct or consequent damages. In this case, the limits and exclusions referred to above do not apply. This limited warranty gives you specific

legal rights, and possibly other rights, which vary depending on local legislation.

Disclaimer

- The information in this manual is provided for informational purposes only. The products described are subject to change without notice from the manufacturer, in order to implement permanent technical improvements.

- LOOK does not provide any warranty or assume any liability in the event of damage related to or caused by the use of this manual or the products it describes.

- LOOK is in no way responsible for any damages, loss, expenses or costs, be they direct or indirect, general, consequential or specific, caused by or related to the use of this manual or the products it describes.

For more information on maintenance requirements, please visit www.lookcycle.com LOOK WARRANTY POLICY section > IMPORTANT INFORMATIONS

COUNTERFEIT WARNING THE USE OF COUNTERFEIT PRODUCTS IS VERY DANGEROUS AND MAY CAUSE YOU AND OTHERS TO HAVE SERIOUS FALLS, RESULTING IN SERIOUS INJURY OR EVEN DEATH.

LOOK products are protected by industrial property rights.

<http://www.lookcycle.com/patents/>

Therefore, in the case of purchase, use, or sale of a counterfeit product, we reserve the right to take any action we deem appropriate to stop the infringement of our rights and obtain compensation for the harm suffered as defined in Articles L613-3 to L613-6, L615-14 and L716-9.

It goes without saying that counterfeit products do not benefit from any LOOK warranty and renders all LOOK warranties on a LOOK compliant product used with counterfeit products null and void. It also renders all accident-related, material, moral, civil and physical responsibilities on the part of LOOK CYCLE INTERNATIONAL null and void.

The sale of products on foreign websites is likely to involve counterfeit products.

To prevent fraud, we advise you to be very vigilant regarding the following (non-exhaustive list):

- Websites offering products marked LOOK at well below market price.

- Sales from private individuals to private individuals that do not include a purchase invoice, maintenance follow-up and information on the origin of the product.

For any help, you can contact us via our website or that of the Distributor for your country (the list of our retailers and Distributors is available on WWW.LOOKCYCLE.COM), providing the serial number and/or photos for verification.

This manual may not be used or reproduced, even partially, in any form or by any means without prior written permission from LOOK.

For more information on the COUNTERFEIT WARNING, please visit www.lookcycle.com SERVICES tab > WARRANTY POLICY > COUNTERFEIT

This equipment is in compliance with the provisions of Directive 93/42/EC.