

Li-ion Cylindrical Battery Specification

锂离子圆柱电池说明书

MODEL

型号: ICR14500-1S1P

Nominal Capacity

标称容量: 800mAh

Draft:
起草: Sam CHEN

Approved:
批准:

Address: 7L, Maple Plaza, #1088, Nanshan Avenue, Nanshan District, Shenzhen, China

地址: 深圳南山区南山大道 1088 号枫叶国际广场 7L 深圳市 Post Code: 518054 邮编: 518054

Website: www.ctech.net.cn Alibaba: www.ctech.en.alibaba.com

TEL : (86) 755-86952385/86952386 FAX : (86) 755-61624235

2.Scope 适用范围

This specification describes the basic performance, technical requirement, testing method, warning and caution of the Li- ion Cylindrical rechargeable battery .The specification only applies to Shenzhen cheape technology internation., Ltd.

本标准规定了圆柱锂离子可充电电池的基本性能、技术要求、测试方法及注意事项，本标准只适用于深圳市驰普科技有限公司。

3. Products assembly drawing and size refers to picture 1

产品组装图及尺寸请参阅图 1

插头型号	线材	保护板型号
Molex51021-2P 正向	UL1571 26#	MT-BFNΦ13.5-1S-G3J-B

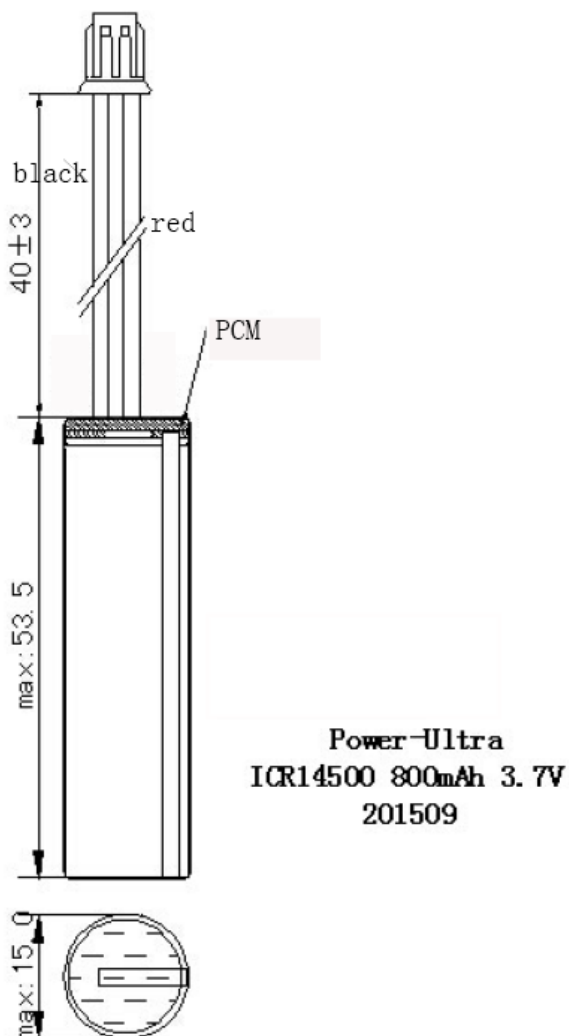

4.Specification 产品规格

NO. 序号	Item 项目	Specifications 规格要求				
4.1	Typical Capacity 典型容量	800mAh @ 0.2C Discharge (0.2C 放电)				
	Minimum capacity 最小容量	780mAh @ 0.2C Discharge (0.2C 放电)				
4.2	Nominal voltage 标称电压	3.7V				
4.3	Standard Charge 标准充电	CC/CV,0.2C5A,4.20V				
4.4	Standard Discharge 标准放电	CC,0.2C5A, 3.00V				
4.5	End-of-charge Voltage 充电截止电压	4.20V±0.1V				
4.6	End-of-charge Current 充电截止电流	0.02C5A (At CV mode)				
4.7	End-of-discharge Voltage 放电截止电压	3.00 V				
4.8	Charging Time 充电时间	8.0hours (standard charge) 8 小时				
4.9	Quick Charge Current 快速充电电流	800mA (1.0C5rate) 1C 充电				
4.10	Quick Discharge Current 快速放电电流	1600mA (2.0C5rate) 2C 放电				
4.11	Max Discharge Current 最大放电电流	2400mA (3.0C5rate) 3C 放电				
4.12	Initial Impedance 初始内阻	Max: 160mΩ				
4.13	Weight 重量	Approx(约): 21±2g				
4.14	Operating temperature 工作温度	Charging(充电): 0°C~45°C Discharging(放电): -20°C~60°C				
4.15	Storage temperature 储存温度	-5°C~35°C				
4.16	Storage Humidity 储存湿度	≤75% RH				
4.17	Appearance 外观	Without scratch, distortion, contamination and leakage (无划痕、变形、污迹、电解液泄露)				
4.18	Standard environmental condition 标准环境	Temperature(温度) : 25±2°C Humidity (湿度) : 45-75%RH Atmospheric Pressure (大气压) : 86-106 KPA				
4.19	Temperature Dependence of Discharge Capacity 放电容量与温度的相互关系 @ 0.2C Discharge (0.2C 放电)					
	25°C	-10°C	0°C	15°C	25°C	40°C
	Relative Capacity	50%	80%	90%	100%	100%

※以上放电容量和倍率只适用于单体电芯

The discharge capacity and rate only applies to single electrical cores

5 General Performance 常规性能

No.	Item 项目	Test Methods and Condition 测试方法和条件	Criteria 标准
5.1	0.2C Capacity	After standard charging, rest battery for 10min, then	≥300min

	0.2C 容量	discharging at 0.2C to voltage 3.0V, recording the discharging time. 标准充饱电后,搁置 10 分钟,然后用 0.2C 电流放电至 3.0V,所记录放电时间	
5.2	Cycle Life 循环寿命	Constant current 0.5C charge to 4.2V, then constant voltage charge to current declines to 0.01C, rest 10min, constant current 0.5C discharge to 3.0V, rest 10min. Repeat above steps till continuously discharging capacity Higher than 80% of the Initial Capacities of the Cells 先用 0.5 C 恒流充电至 4.2V, 再恒压 4.2V 充电直至充电电流 $\leq 0.01C$, 搁置 10 分钟,再用 0.5C 电流放电至 3.0V; 又搁置 10 分钟, 重复以上步骤, 直到放电容量是初始容量的 80%	≥ 300 times(次)
5.3	Capability of keeping electricity 荷电保持能力	$20 \pm 5^\circ\text{C}$, After standard charging, rest the battery 28days, discharging at 0.2C to voltage 3.0V, recording the discharging time. 在 $20 \pm 5^\circ\text{C}$ 状态下,标准充饱电后,电芯搁置 28 天,然后用 0.2C 放电至 3.0V,所记录放电时间.	≥ 240 min

6 Environment Performance 环境性能

No.	Item 项目	Test Methods and Condition 测试方法和条件	Criteria 标准
6.1	Discharge at high temperature 高温放电	After standard charging, rest the cells 4h at $60 \pm 2^\circ\text{C}$, then discharging at 1C to voltage 3.0V, recording the discharging time. 标准充电后, 在 $60 \pm 2^\circ\text{C}$ 条件下贮存 4h, 然后用 1C 放电至 3.0V, 所记录放电时间.	≥ 54 min
6.2	Discharge at low temperature 低温放电	After standard charging, rest the cells for 16h at $-20 \pm 2^\circ\text{C}$, then discharging at 0.2C to voltage 3.0V, recording the discharging time. 标准充电后, 在 $-20 \pm 2^\circ\text{C}$ 条件下贮存 16h, 然后用 0.2C 放电至 3.0V, 所记录放电时间.	≥ 210 min
6.4	Thermal shock 热冲击	Put the cells in the oven. The temperature of the oven is to be raised at $5 \pm 2^\circ\text{C}$ per minute to a temperature of $130 \pm 2^\circ\text{C}$ and remains 30 minutes. 将电池放进烘箱内, 以 $5 \pm 2^\circ\text{C}/\text{min}$ 速度升高烘箱内温度至 $130 \pm 2^\circ\text{C}$ 后, 恒温 30min.	No fire, no smoke 不起火,不冒烟

7 Safe Characteristic 安全性能

No.	Item 项目	Test Methods and Condition 测试方法和条件	Criteria 标准
7.1	Over charge testing 过充测试	At $23 \pm 5^\circ\text{C}$, charging cells with constant current 2C to voltage 5.0V, Stop test till cells temperature 10°C lower than max temperature. 在 $23 \pm 5^\circ\text{C}$ 状态下, 电池用 2C 电流充电至 5.0V, 监视电池温度变化, 当电池温度下降一峰值低约 10°C 时, 停止实验.	No smoke or fire 不起火,不冒烟
7.2	Over discharge	At $23 \pm 5^\circ\text{C}$, According to the requirements of standard	No fire, no smoke, no

	testing 过放测试	charge, the cells will be discharge to cut-off voltage, then connect with external load of 30 ohm for 24 hours. 在 23±5℃状态下, 按标准放电的要求放电至终止电压后, 外接 30Ω 负载放电 24 小时.	leakage. 无起火, 无冒烟, 无泄液
7.3	Short-circuit testing 短路测试	At 23±5℃, After standard charging, connect cells anode and cathode by wire which impedance less than 80±20mΩ, keep 6h. 在 23±5℃状态下, 标准充电后, 将电池的正负极用一根小于 80±20mΩ 的导线连接, 放置 6 小时.	No smoke or fire 不起火, 不冒烟

※ Above testing of safe characteristic must be with protective equipment.(安全性能测试应在有保护措施下进行)

8. Protective circuits 保护电路

8.1 PCM Standard (保护板标准):

保护IC: Protection IC:	S-8261ABJMD-G3JT2G	参数值 parameter value			
		常温25℃ General temperature 25℃			
项目 item	最小值 Min.	典型值 Type value	最大值 Max.	单位 Unit	
过充保护电压 Over charge protection voltage	4.255	4.280	4.305	V	
过充保护恢复电压 Over charge release voltage	4.055	4.080	4.105	V	
过放保护电压 Over discharge protection voltage	2.95	3.00	3.05	V	
过放保护恢复电压 Over discharge release voltage	2.95	3.00	3.05	V	
放电过流检测电压 Over current detection voltage	0.065	0.080	0.095	V	
放电过流保护电流 Over current protection current	1.0	2.0	3.0	A	
过充保护延迟时间 Over charge protection delay time	0.96	1.2	1.4	s	
过放保护延迟时间 Over discharge protection delay time	115	144	173	ms	
放电过流保护延迟时间 Over current protection delay time	7.2	9.0	11	ms	
短路保护延迟时间 Short protection delay time	220	320	380	us	
正常状态下静态电流 Current consumption (Operation)		3.5	7.0	uA	
过放状态下静态电流 Current consumption (Power down)			0.1	uA	
导通内阻 Impedance		25	50	mΩ	
输入电压(B+与B-间) Input voltage(B+ to B-)	-0.3		12	V	
最大持续充电电流 Max continuous charge current			1.0	A	
最大持续放电电流 Max continuous discharge current			1.0	A	

9. CAUTIONS IN USE 使用警告

To ensure proper use of the battery please read the manual carefully before using it. Handling
 为了使电池安全的使用及处理请在使用前认真的阅读操作说明

- Do not expose to, dispose of the battery in fire.
- 不能把电池曝晒或丢在火中
- Do not put the battery in a charger or equipment with wrong terminals connected.
- 电池充电时不能把正负极性装反
- Avoid shorting the battery
- 避免短路电池
- Avoid excessive physical shock or vibration.
- 避免过分的物理震动和冲击电池
- Do not disassemble or deform the battery.

- 不能拆解或使电池变形
- Do not immerse in water.
- 不能将电池浸入水中
- Do not use the battery mixed with other different make, type, or model batteries.
- 不能将其它不同厂家，类型，型号的电池混合使用
- Keep out of the reach of children.
- 禁止小孩接触电池

charge and discharge 充放电

- Battery must be charged in appropriate charger only.
- 电池必须在合适的条件下充电
- Never use a modified or damaged charger.
- 决不能用故障的充电器给电池充电
- Do not leave battery in charger over 24 hours.
- 电池持续充电不能超过 24H

. storage 贮存

- Store the battery in a cool, dry and well-ventilated area.
- 电池贮藏在通风干燥的环境中

. disposal 处理

- Regulations vary for different countries. Dispose of in accordance with local regulations.
- 不同国家法规的不同，处理时根据当地的法规。

10. Battery operation instruction 电池操作说明

10.1 Charging 充电

Charging current: Cannot surpass the biggest charging current which in this specification book stipulated.

充电电流：不能超过规格书规定的最大的充电电流

Charging voltage: Does not have to surpass the highest amount which in this specification book stipulated to decide the voltage.

充电电压：不能超过规格书规定的最高的限制电压

Charge temperature: The battery must carry on the charge in the ambient temperature scope which this specification book stipulated.

充电温度：电池充电温度必须按照规格书的温度范围执行

Uses the constant electric current and the constant voltage way charge, the prohibition reverse charges. If the battery positive electrode and the cathode meet instead, can damage the battery.

先恒流后恒压方式充电，禁止颠倒的方式充电。如果电池正负极颠倒充电会带来危险。

10.2 Discharging current 放电电流

The discharging current does not have to surpass this specification book stipulation the biggest discharging current, the oversized electric current electric discharge can cause the battery capacity play to reduce and to cause the battery heat.

电池放电电流不能超过规格书规定的最大放电电流，过大的电流放电会造成电池发热和容量衰减。

10.3 discharge temperature 放电温度

The battery discharge must carry on in the ambient temperature scope which this specification book stipulated

电池放电温度必须按照规格书的温度范围执行

10.4 Over-discharges 过放电

After the short time excessively discharges charges immediately cannot affect the use, but the long time excessively discharges can cause the battery the performance, battery function losing. The battery long-term has not used, has the possibility to be able to be at because of its automatic flashover characteristic certain excessively discharges the condition, for prevented excessively discharges the occurrence, the battery should maintain the certain electric quantity.

短时间的的过充过放不影响电池的使用，但是长时间的过放电会影响到电池的功能失效，电池永久性不能适

用，电池可能过放还有一个原因是自动能量的消失。预防电池过放的出现方法是电池应保持一定的电量。

10.5 Storing the Batteries 贮存电池。

The battery should store in the product specification book stipulation temperature range. If has surpasses above for six months the long time storage, suggested you should carry on additional charge to the battery.

电池贮存在规格书规定的温度范围内，如果电池贮存超过六个月，建议你开始给电池充电。

11. Period of Warranty 保质期

The period of warranty is one year from the date of shipment. guarantees to give a replacement in case of cells with defects proven due to manufacturing process instead of the customers abuse and misuse.

电池的保质期从出货之日算起为 1 年。如果证明电池的缺陷是在制造过程中形成的而不是由于用户滥用及错误使用造成，本公司负责退换电池。

12. Other The Chemical Reaction 其它化学反应

Because batteries utilize a chemical reaction, battery performance will deteriorate over time even if stored for a long period of time without being used. In addition, if the various usage conditions such as charge, discharge, ambient temperature, etc. are not maintained within the specified ranges the life expectancy of the battery may be shortened or the device in which the battery is used may be damaged by electrolyte leakage. If the batteries cannot maintain a charge for long periods of time, even when they are charged correctly, this may indicate it is time to change the battery.

由于电池是利用化学反应的原理，所以随时间的增加电池的性能会降低，即使是存放很长一段时间而不使用。如果使用条件如充电、放电及周围环境温度等情形不在指定的使用范围内，也会缩短电池的使用寿命，或者产生漏液导致设备损坏。如果电池长周期不能充电，即使充电方法正确，这样需要更换电池了。

13.Note: 备注

Any other items which are not covered in this specification shall be agreed by both parties.

本说明书未包括事项应由双方协议确定。